

# ASSEMBLY INSTRUCTION

## ASTORIA

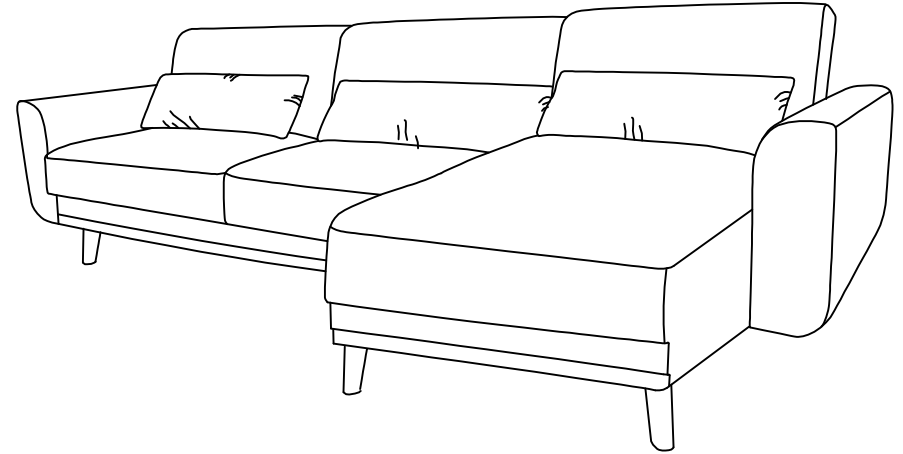

### ASSEMBLY INSTRUCTIONS

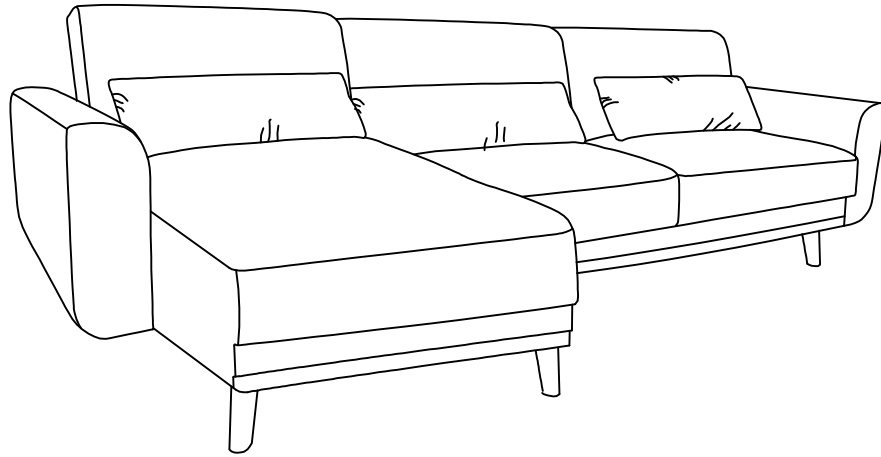

#### PARTS AND HARDWARE

Note: Individual parts are not shown to scale.

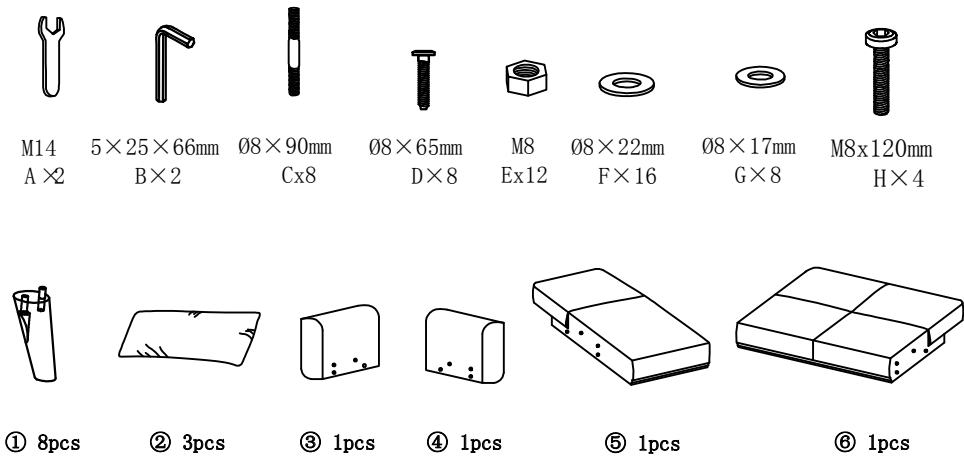

#### Step 1

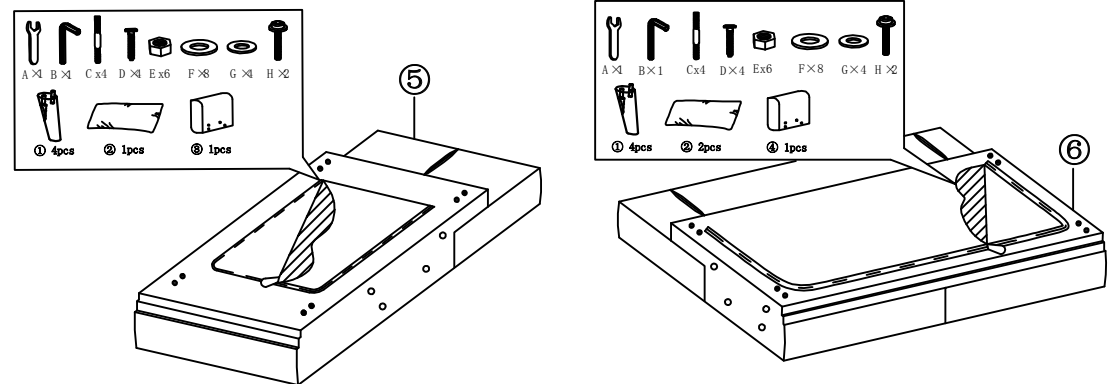

# OPERATING YOUR UNIT

Step 2

Step 3

Step 4

Step 5

Step 6

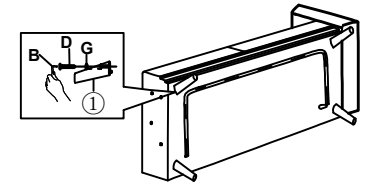
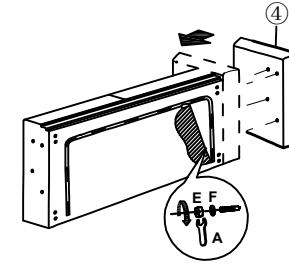
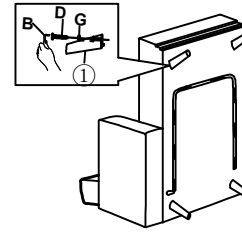
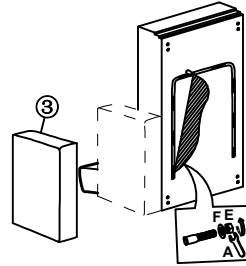
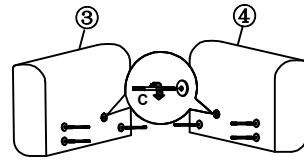
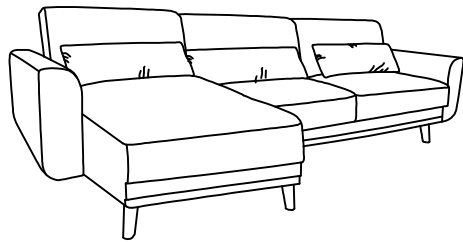

Step 2

Step 3

Step 4

Step 5

Step 6

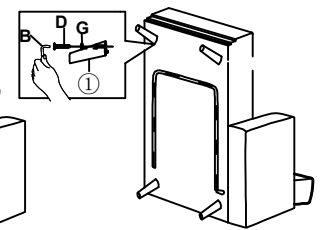
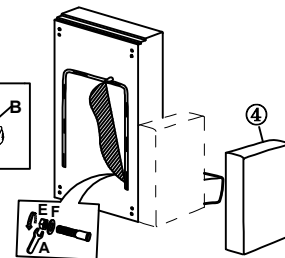
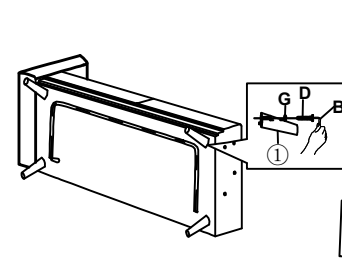
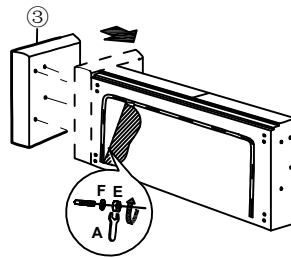
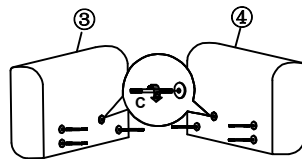
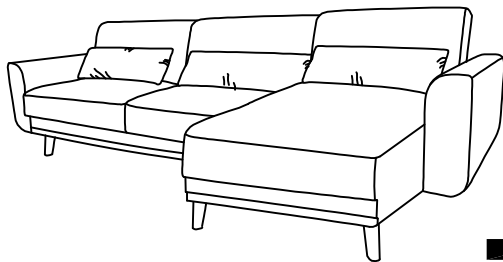

# OPERATING YOUR UNIT

Step 7

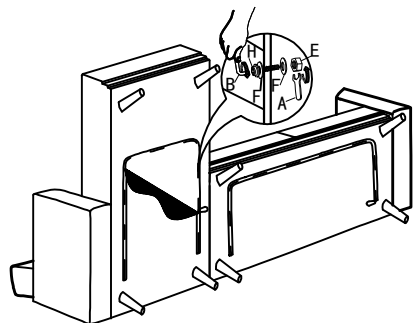

Step 8

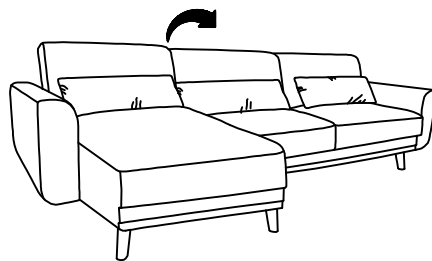

Step 9

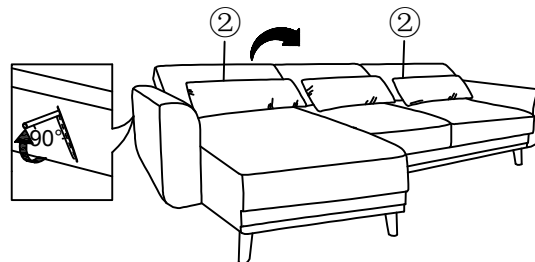

Step 10

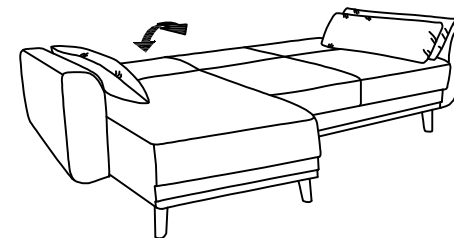

Step 7

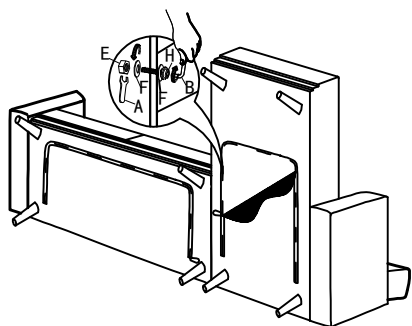

Step 8

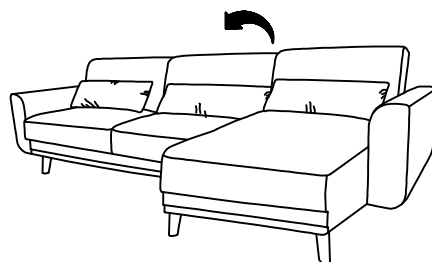

Step 9

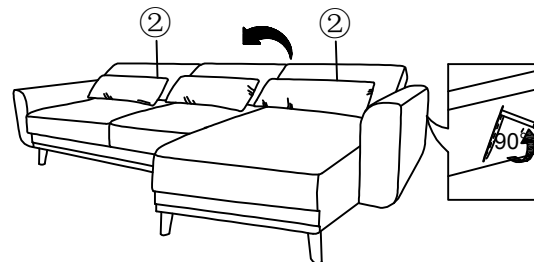

Step 10

